

Bleach Load Trial on D0 Stage

Wisconsin Rapids

Philip Sekerak & Brittany Gagas



About Us

Brittany Gagas

- ❖ Pulp Mill Area Manager at the Wisconsin Rapids Mill
- ❖ BS Chemical Engineering (University of Wisconsin)
- ❖ Born and raised in Stevens Point, WI
- ❖ In pulping industry for a little over two years
- ❖ Hobbies: Ski boat, dog, wedding planning, baking

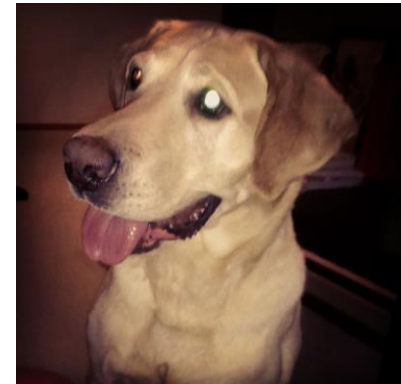
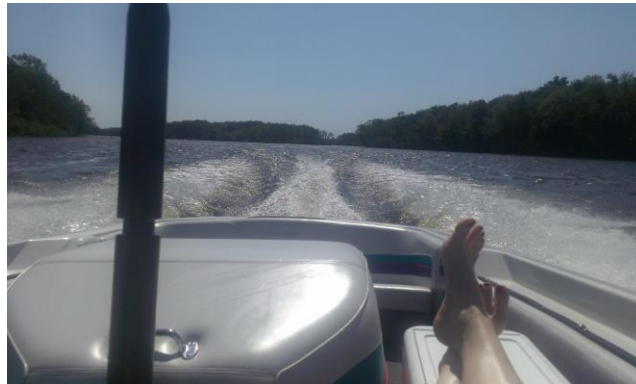
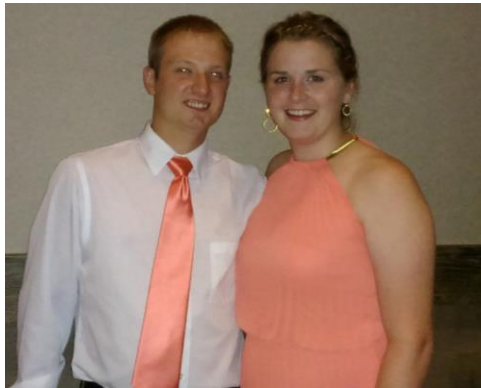

Trial Milestones

- A bleach load transmitter (fiber and filtrate kappa) was installed on January 14, 2014 on the D0 stage of the #2 Fiberline at the Wisconsin Rapids Pulp Mill
- Trial was started and ran through numerous digester cooking modifications (from modified to conventional to downflow)
- New analyzer indication was substituted into the current control logic in place of the existing kappa measurement.
- Initially, it was thought that one calibration curve would serve for both hardwood and softwood species. Through testing, this was found to not be the case.
- Further testing showed that analyzer will work for both species – just need separate calibration curves
- Currently in the process of moving our current analyzer to the DEK position on the #1 Fiberline and purchasing a second to go on the inlet of the D0 stage on that line

Wisconsin Rapids Softwood Kraft Pulping Fiber Line 2 (Page 5 of 6: Wash Press and D0 Tower)

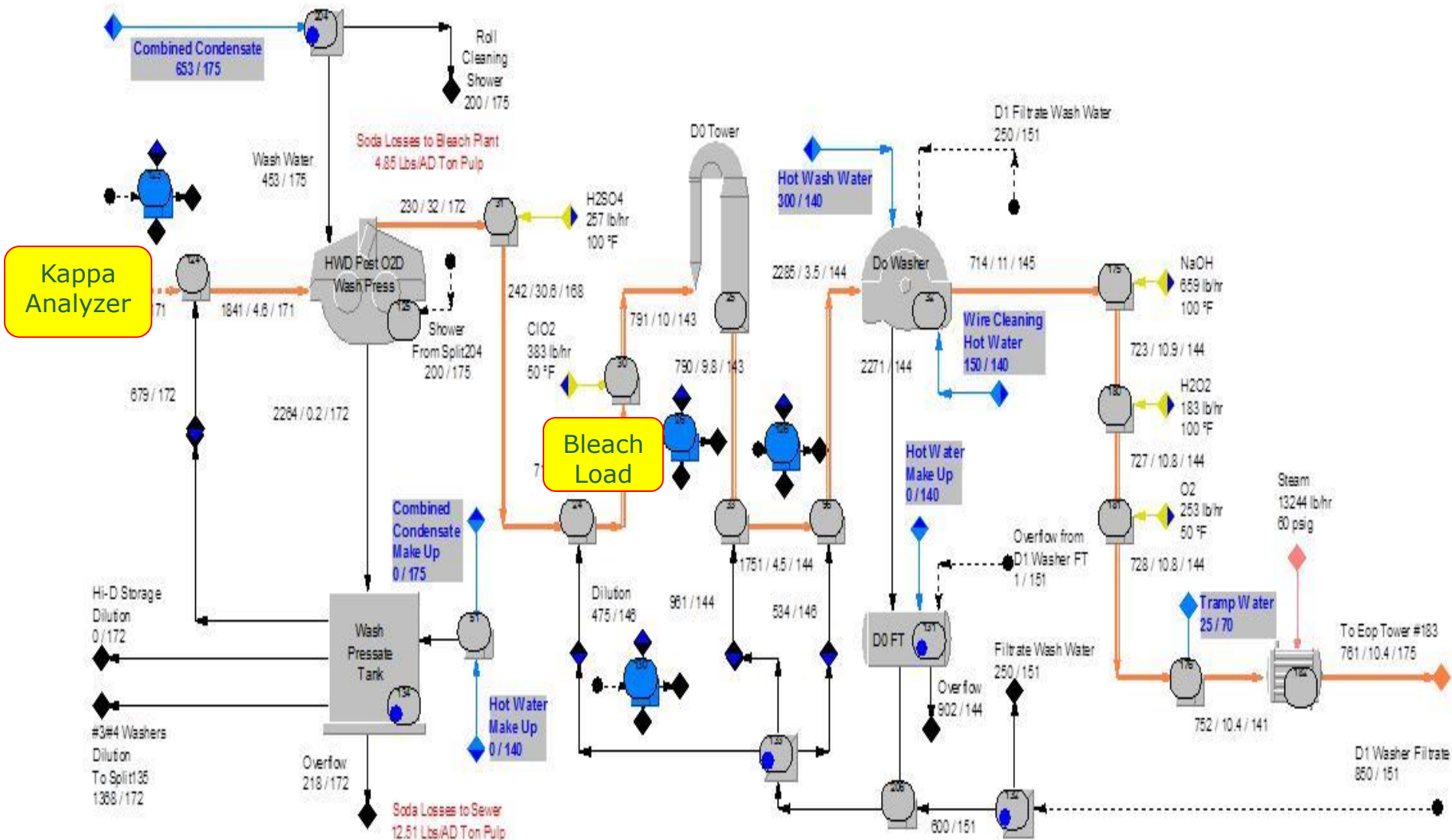

Calibration Testing Procedure

- 4 tests completed on each sample
 - Consistency
 - Fiber kappa analysis
 - Filtrate kappa analysis
 - Brightness

$$\text{Bleach Load} = \text{Fiber Kappa (per g)} + \text{Filtrate Kappa (per g)}$$

$$\text{Filtrate Kappa (per g)} = \text{Filtrate Kappa (per mL)} \times \frac{1 - \text{Consistency}}{\text{Consistency}}$$

Calibration (Both HWK & SWK)

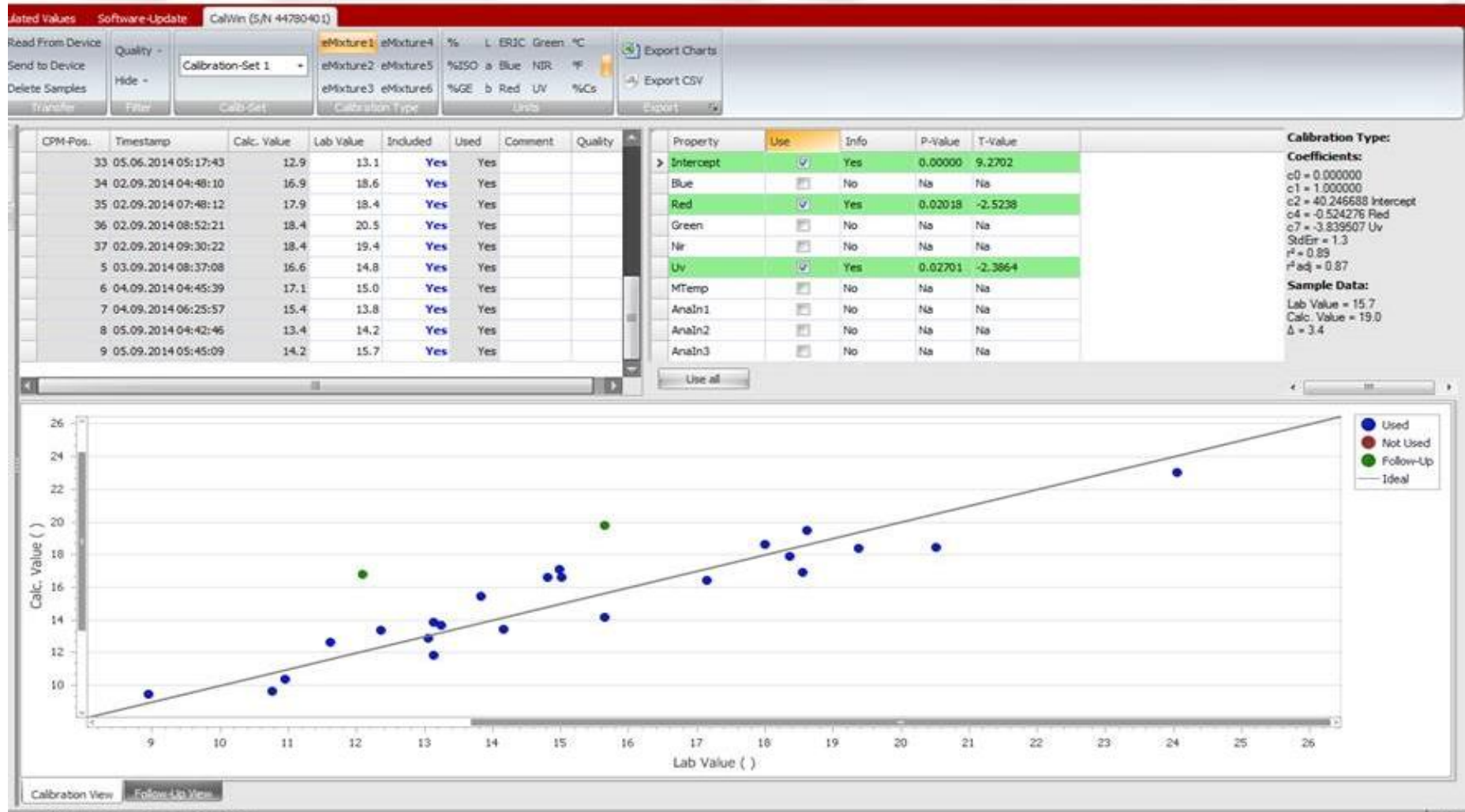

Separating Out Species

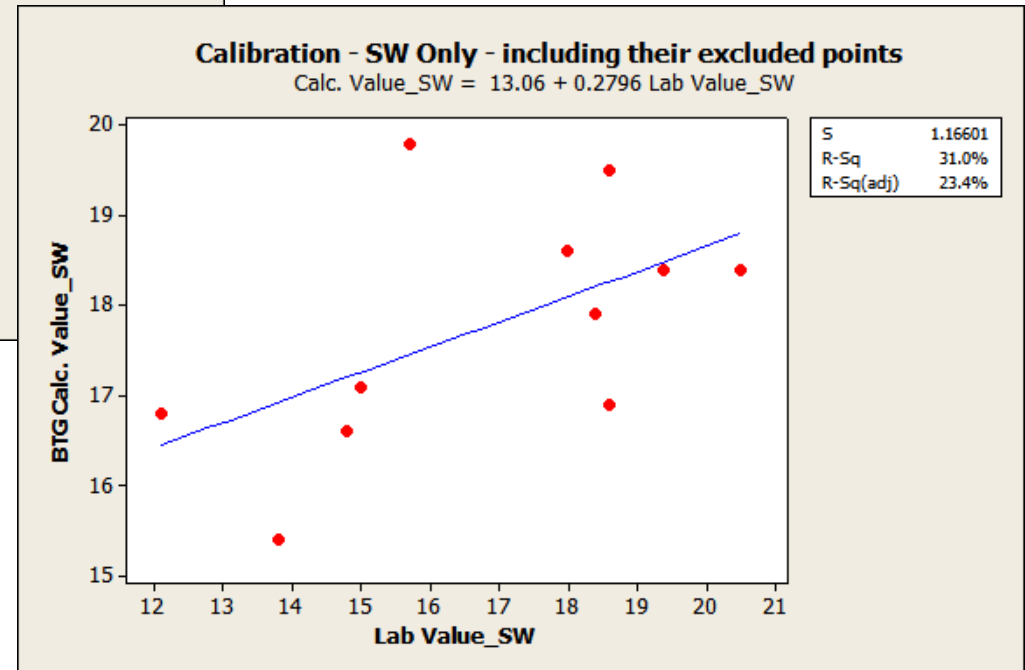
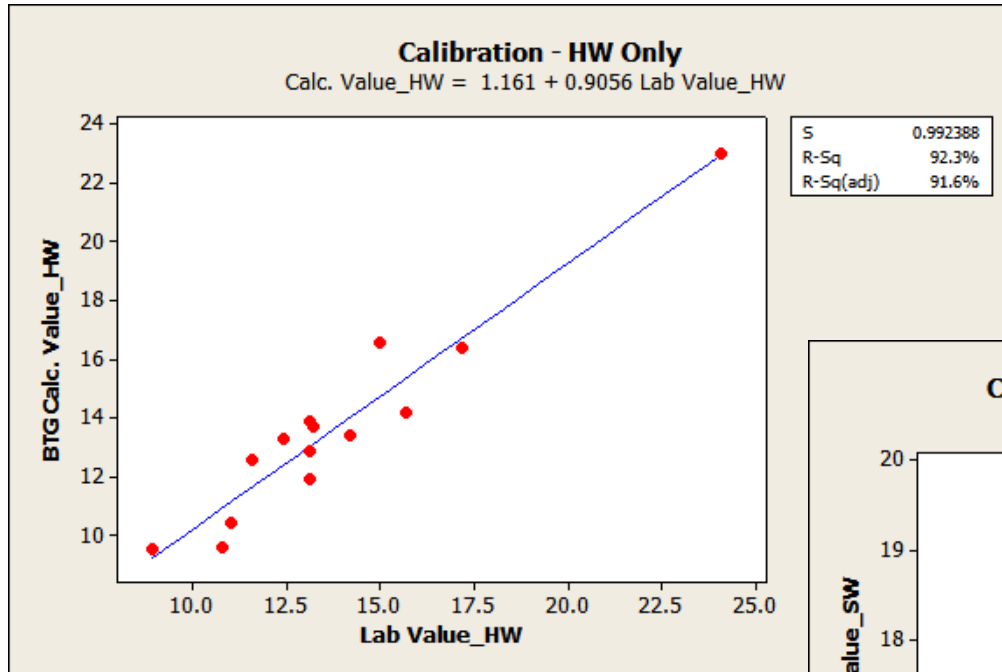

Separating Out Species

- Continued testing of softwood on one digester cooking method proved that a calibration curve could be generated

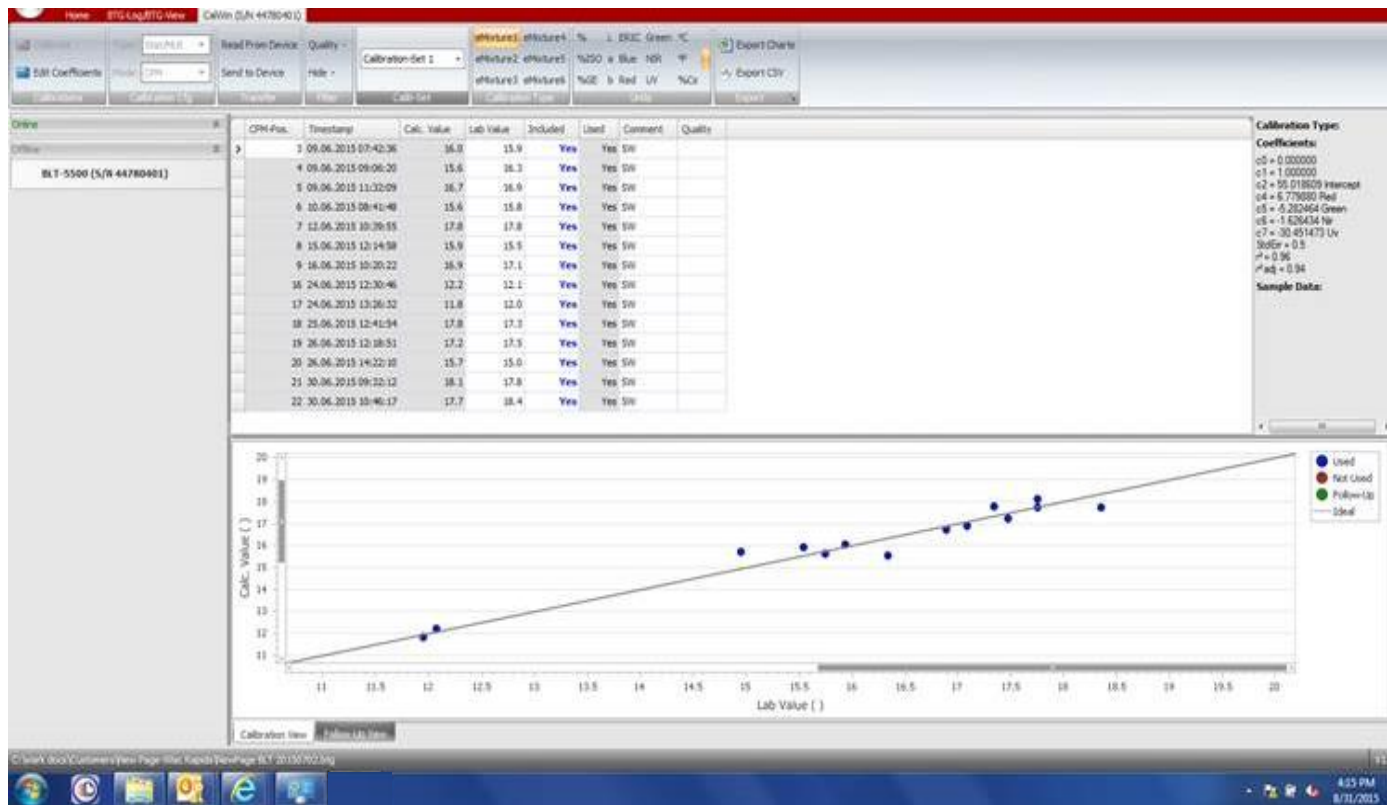

Operator Bias

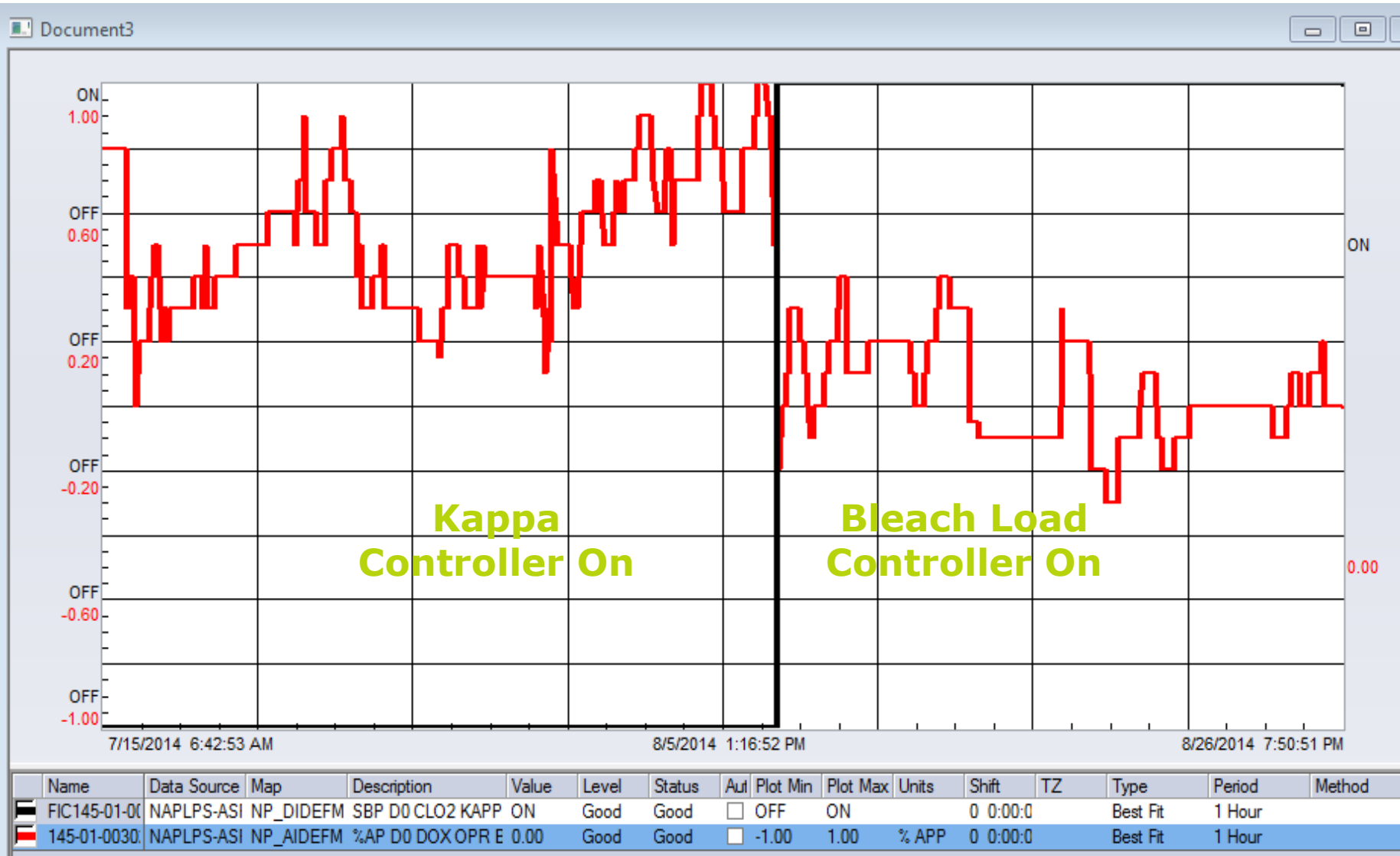

Operator Bias is compensating for Filtrate Kappa

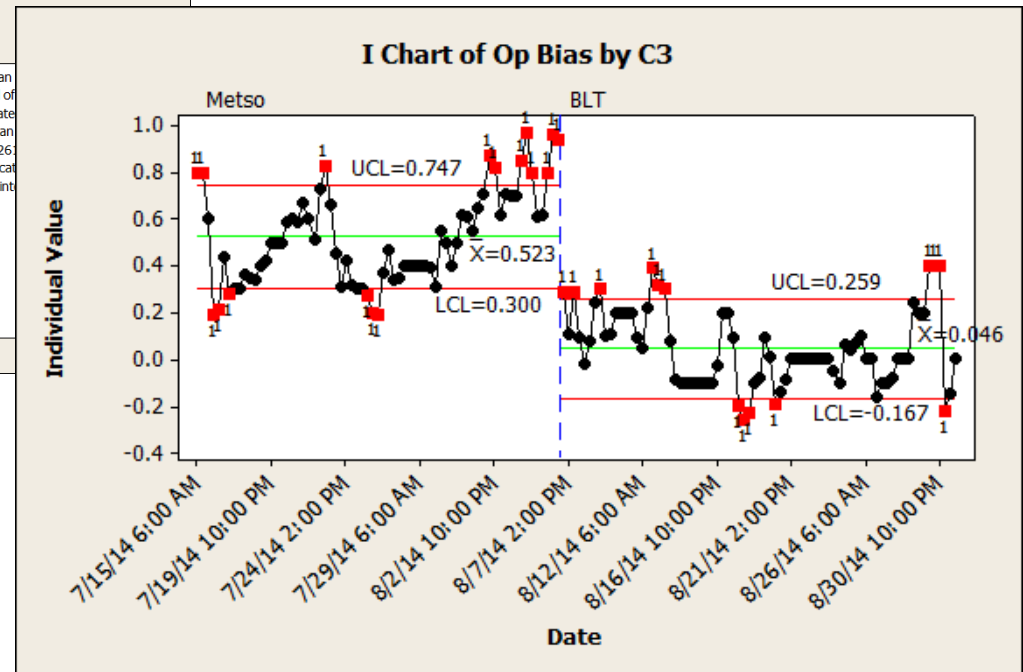
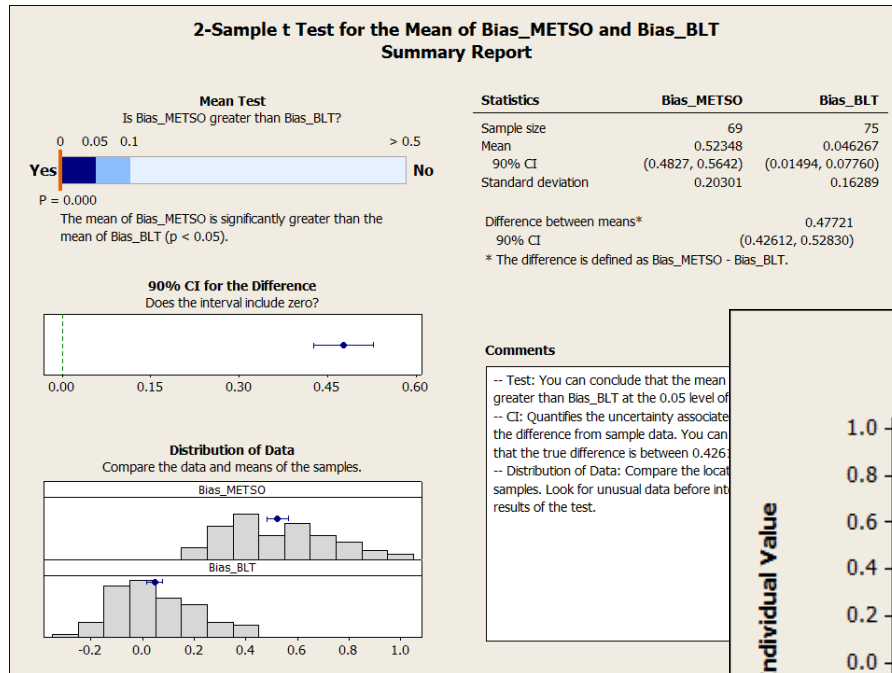

Moving Forward - #1 Bleach Plant

- Currently no kappa measurement on bleach plant
- Runs all HWK
- Prior to ozone elimination, was a four stage (ZEDD) bleach plant
- Ozone elimination converted bleach plant to a three stage (DED) bleach plant
- One additional analyzer was purchased for control of ClO₂ application of both D stages
- Currently collecting data to develop controls

Conclusions

- Successfully measures fiber kappa and filtrate kappa – responds to changes in washing
- Acceptable for both HWK and SWK
 - Two calibration curves will be needed
- Continuous measurement with less need for operator bias adjustments
- More to come