



# **The Impact of Dissolved Lignin on O2 and D0 Stages**

## **2015 PAPTAC Fall Bleaching Committee Meeting**

### **Nanaimo, B.C**

**Presented by:**  
**Rick Van Fleet**  
**Fiber Line Business Manager**  
**BTG Americas, Inc.**

# Introduction

---

- It is well known that the fiber kappa number is very important in determining bleach demand, it has been shown that the filtrate or carryover contribution must also be considered
- Previous work has focused on the total lignin content or the Bleach Load (fiber plus filtrate kappa)
- It was noticed that the filtrate kappa levels varied significantly and rather quickly
- A study was commissioned to determine if the impact of each was similar

# Oxygen Delignification

- Sampling position for laboratory trials
  - Fiber + filtrate

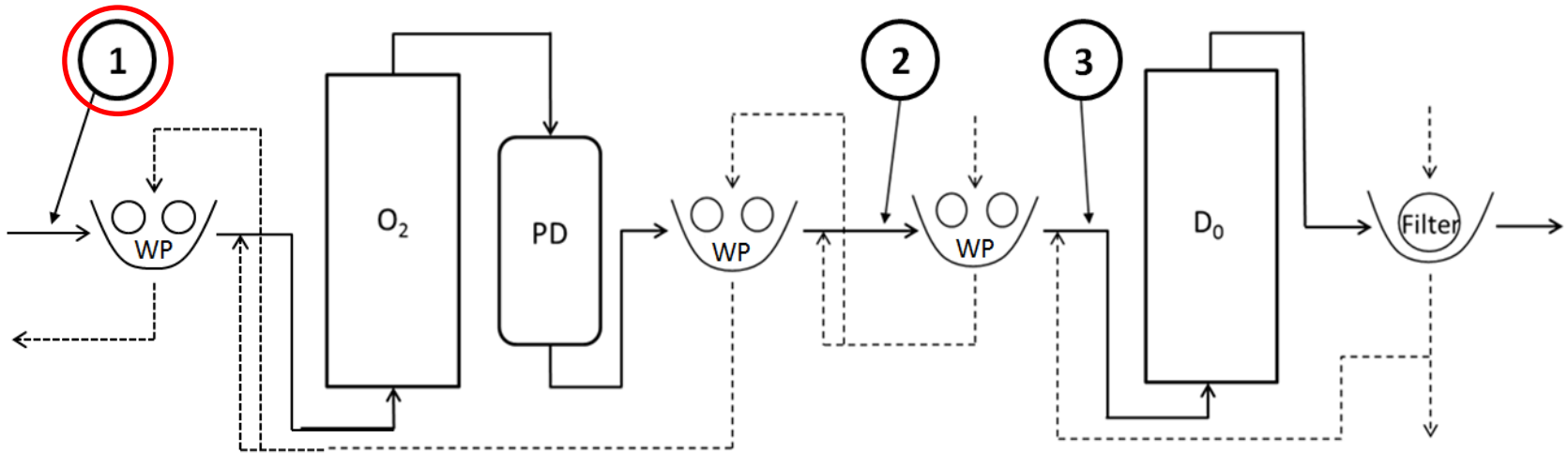

# Research background

---

- Cooking – SW Kappa 30:
  - 1000 kg Wood = ~270 kg Lignin
  - ~500 kg Pulp
- Mass balance
  - ~25 kg Lignin in Pulp
  - ~245 kg Dissolved Lignin
- Pulp washing never perfect
  - How does the Dissolved Lignin impact  $O_2$  and  $D_0$  stages?



# Impact on Chlorine Dioxide stages

- Total Bleach Load = Total Kappa number

Filtrate Kappa [**per mL filtrate**]  $\Leftrightarrow$  Filtrate Kappa [**per g fiber**]

– *Compare COD*

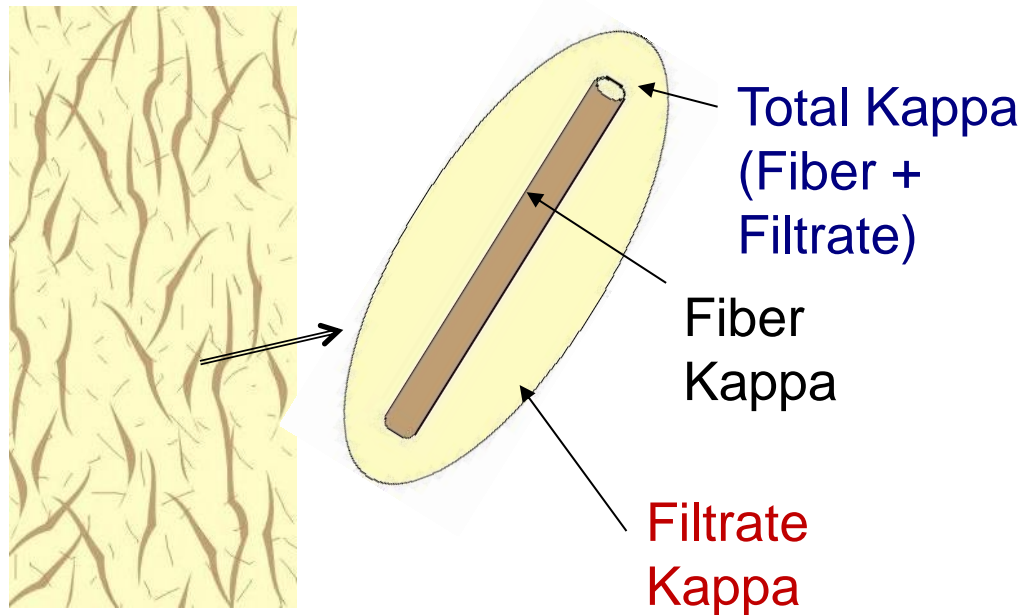

# Impact on Chlorine Dioxide stages

- Laboratory Bleaching Experiments ( $O_2$ -del SW Pulp)
  - Conventional Kappa factor

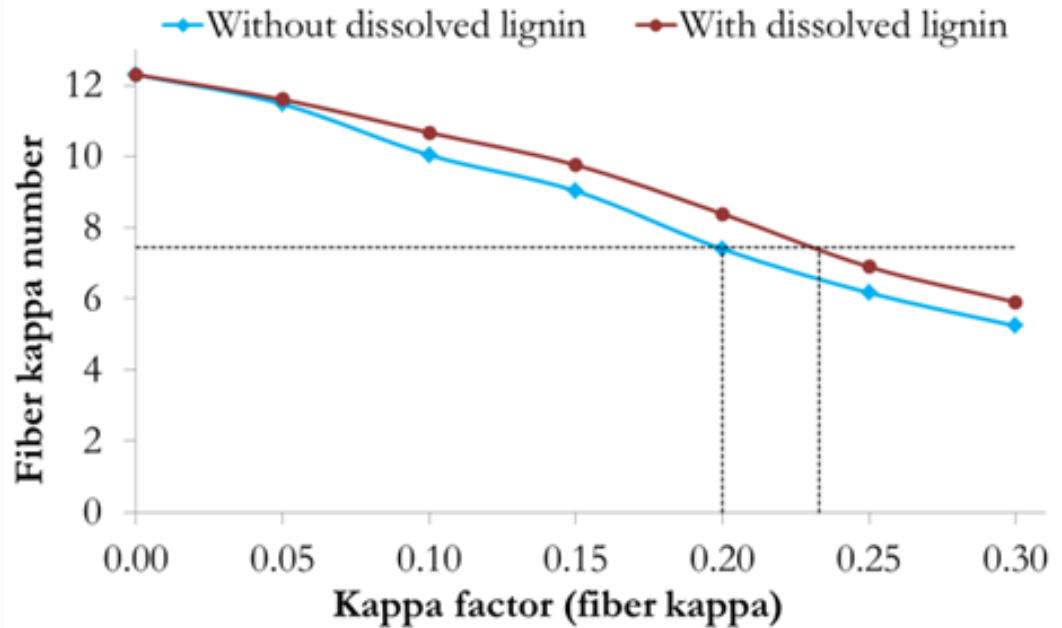
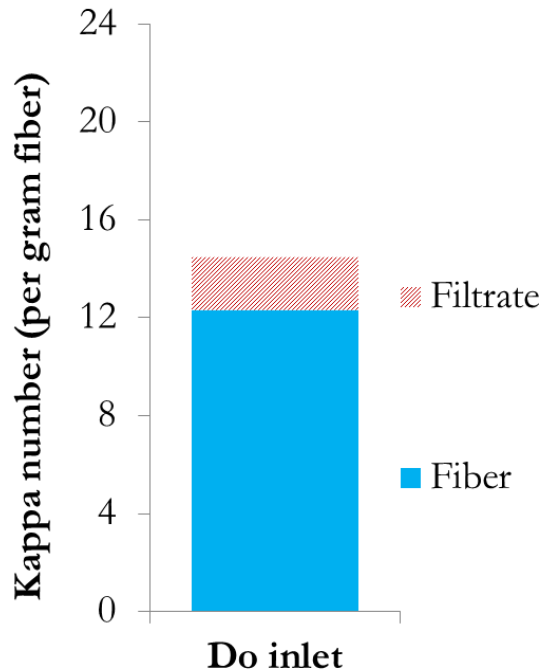

# Impact on Chlorine Dioxide stages

- Laboratory Bleaching Experiments ( $O_2$ -del SW Pulp)
  - 'Total Kappa factor'

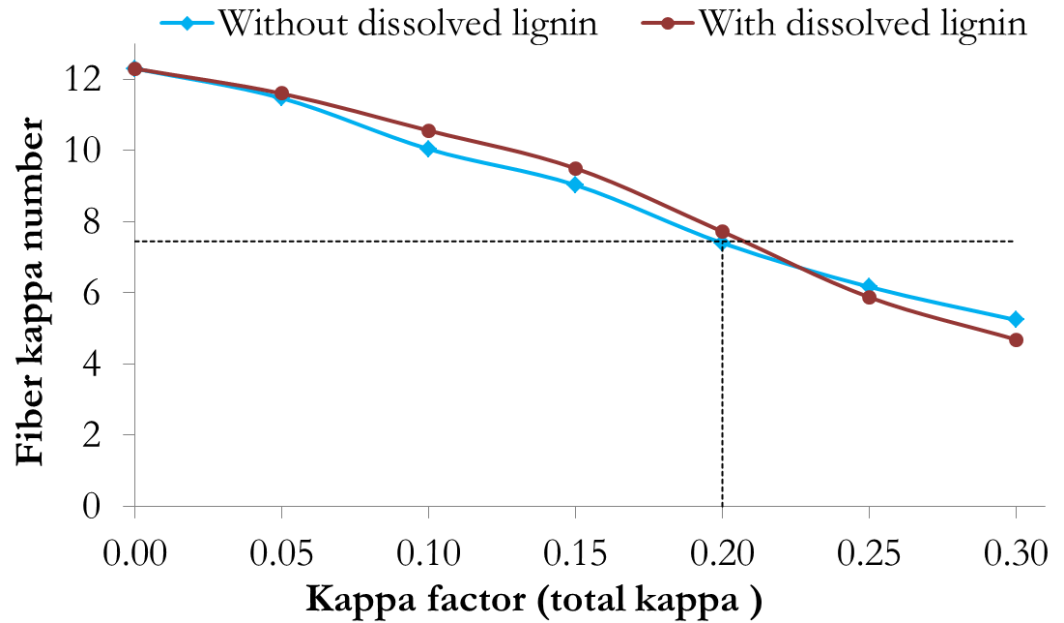
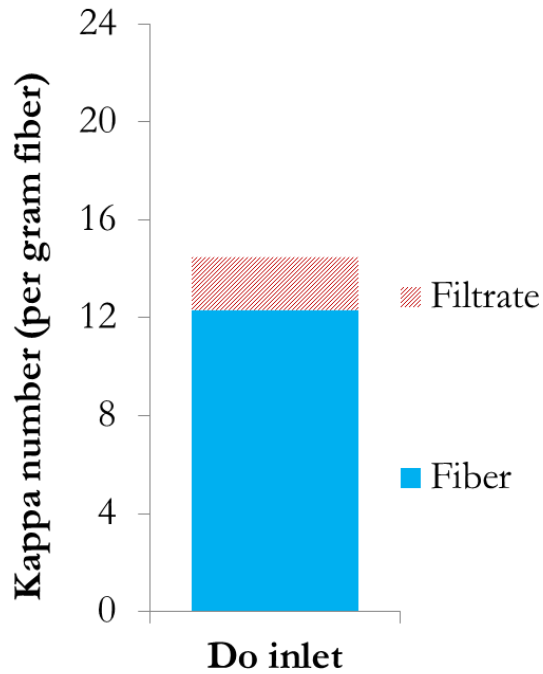

# Impact on Chlorine Dioxide stages

- Verify Filtrate Kappa vs. additional  $\text{ClO}_2$  demand
  - Pre-wash pulp  $D_0$  inlet

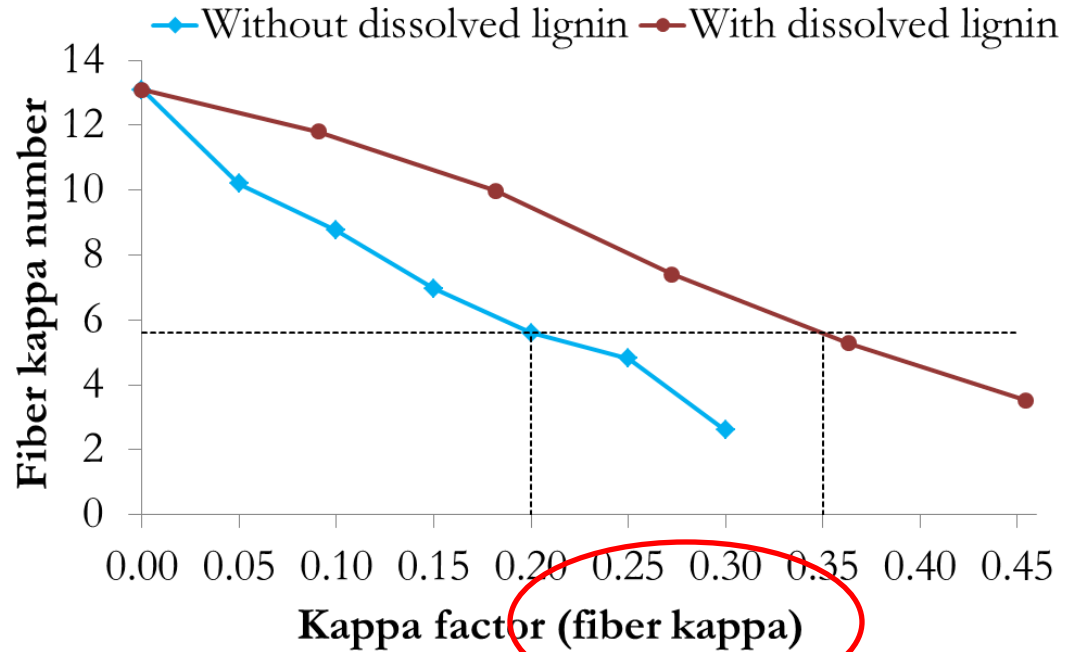
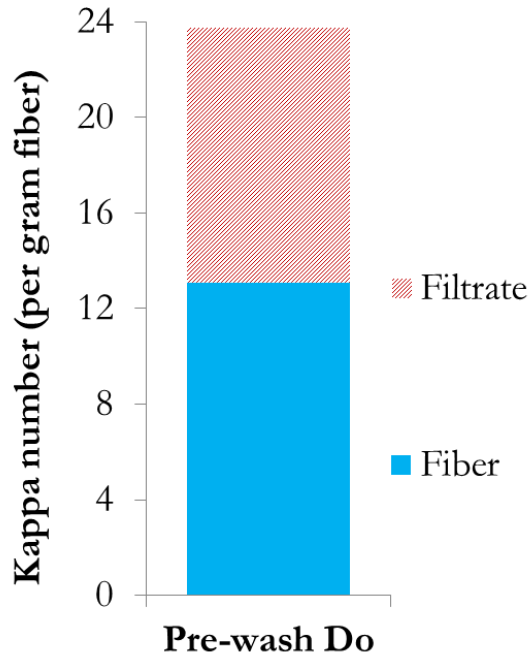

# Impact on Chlorine Dioxide stages

- Verify Filtrate Kappa vs. additional  $\text{ClO}_2$  demand
  - Pre-wash pulp  $D_0$  inlet

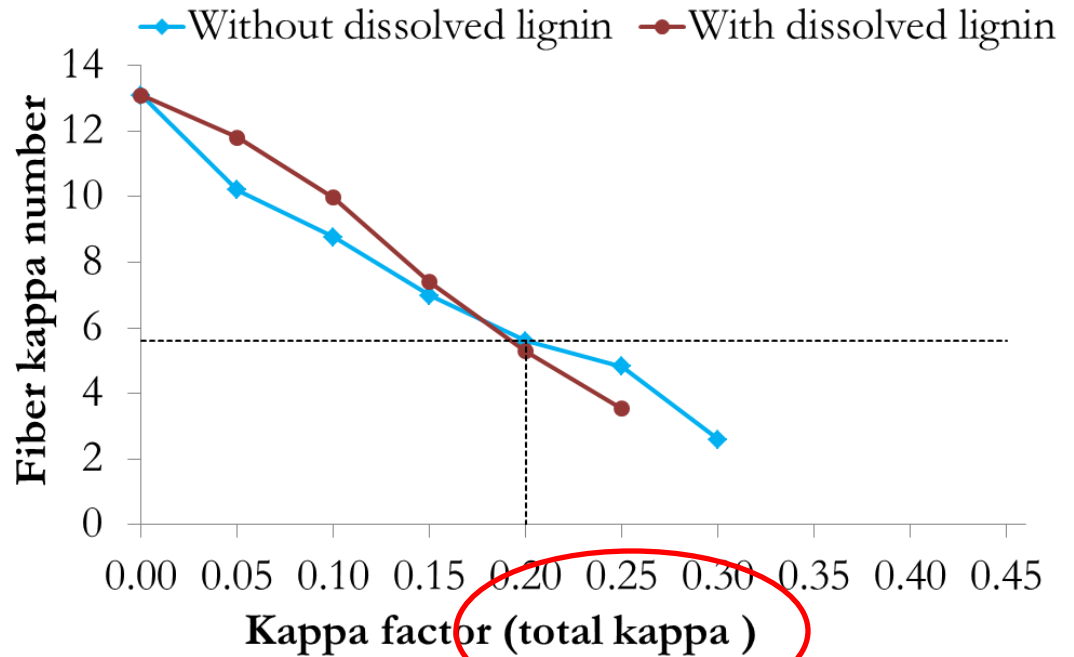
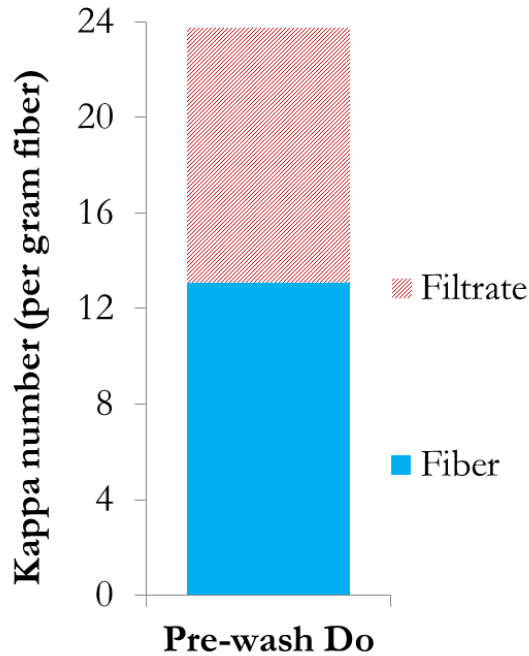

# Impact on Chlorine Dioxide stages

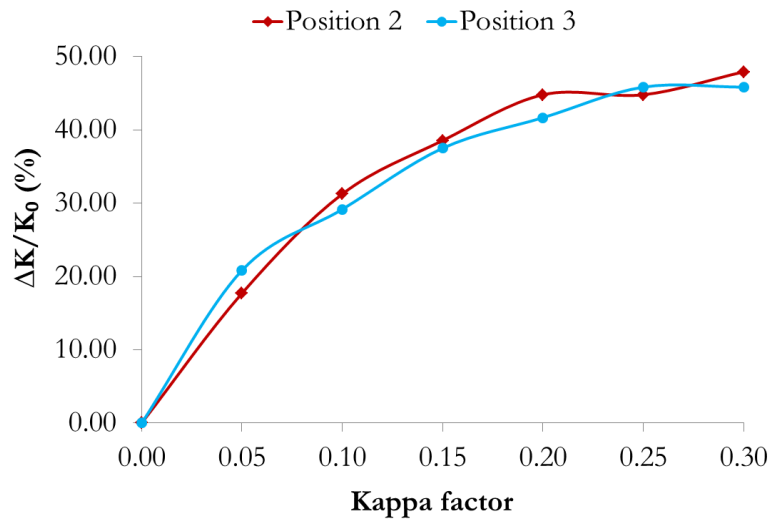

Pre-wash filtrate and Do feed filtrate react similarly vs. ClO<sub>2</sub> charge

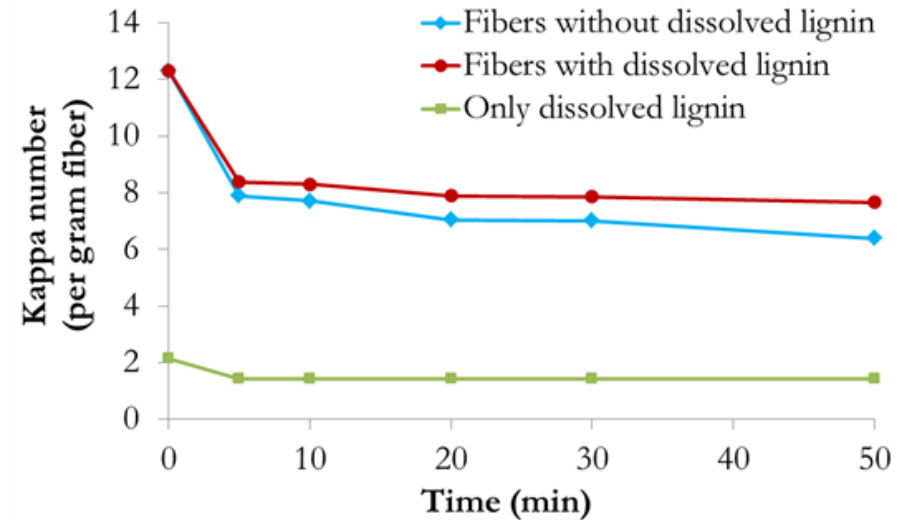

Filtrate and fiber behave similarly vs. time

# Impact on Chlorine Dioxide stages

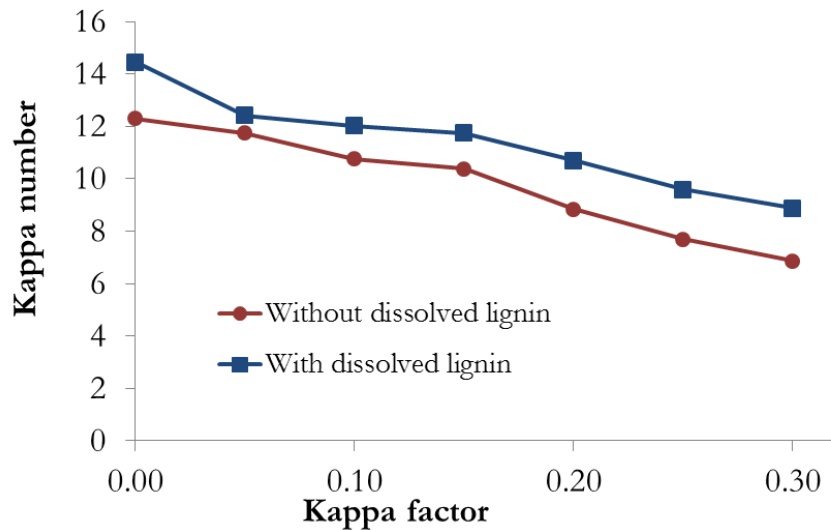

**Total Kappa vs. ClO<sub>2</sub>, with and w/o Dissolved Lignin**

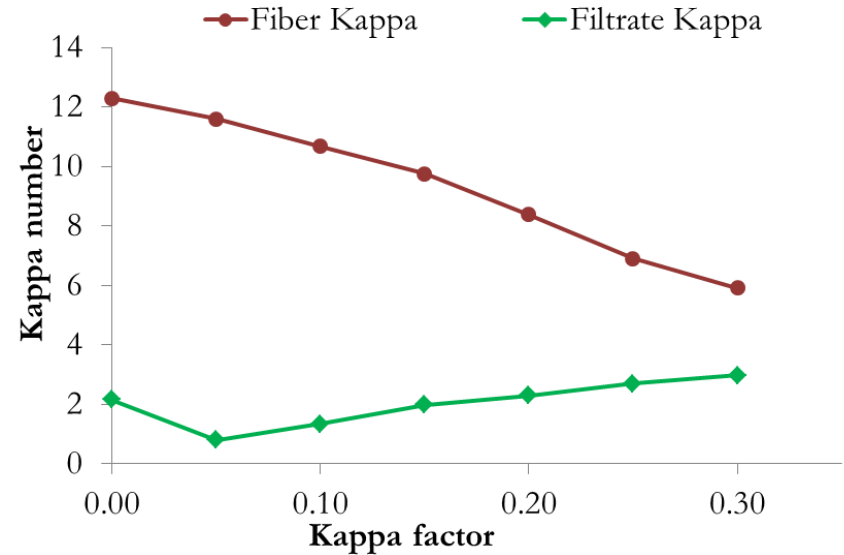

**With Dissolved Lignin,  
~1/3 of the Residual Kappa  
in the D0 filtrate**

# Impact on Chlorine Dioxide stages

## *Conclusions*

Results support mill data showing that  $D_0$  stage control based on Total Kappa is beneficial and yields lower chemical consumption

- Less active feedback control
- Less manual KF adjustments

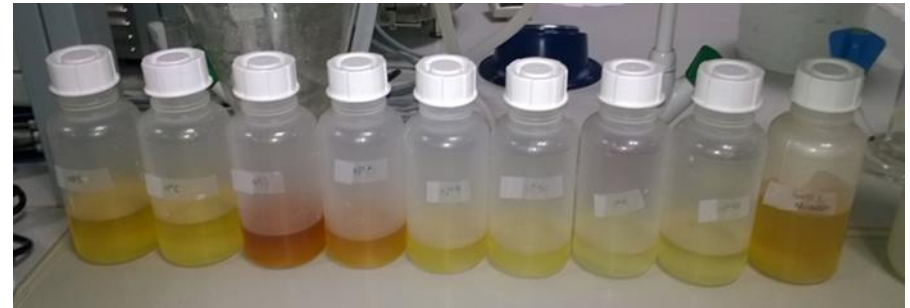
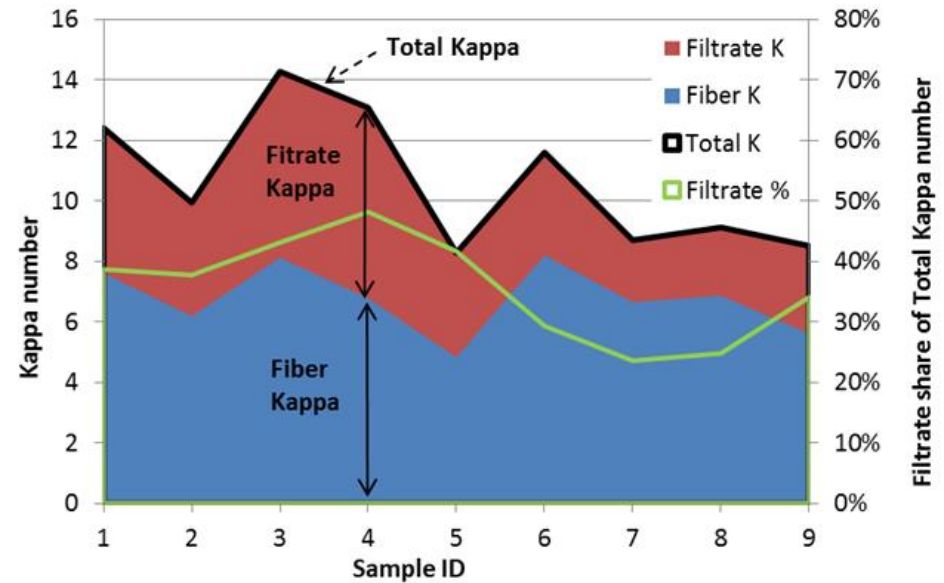

# Total Bleach Load = Fiber Kappa + Filtrate Kappa



Fiber Kappa	7.61	6.19	8.12	6.78	4.83	8.20	6.65	6.86	5.61
Filtrate Kappa	4.80	3.75	6.15	6.30	3.45	3.40	2.05	2.26	2.90
Total Kappa	12.41	9.94	14.27	13.08	8.28	11.60	8.70	9.12	8.51
Filtrate Kappa Percentage (%)	39%	38%	43%	48%	42%	29%	24%	25%	34%

# Oxygen Delignification

- Variability is significant (47 days, SW kraft O<sub>2</sub> feed)

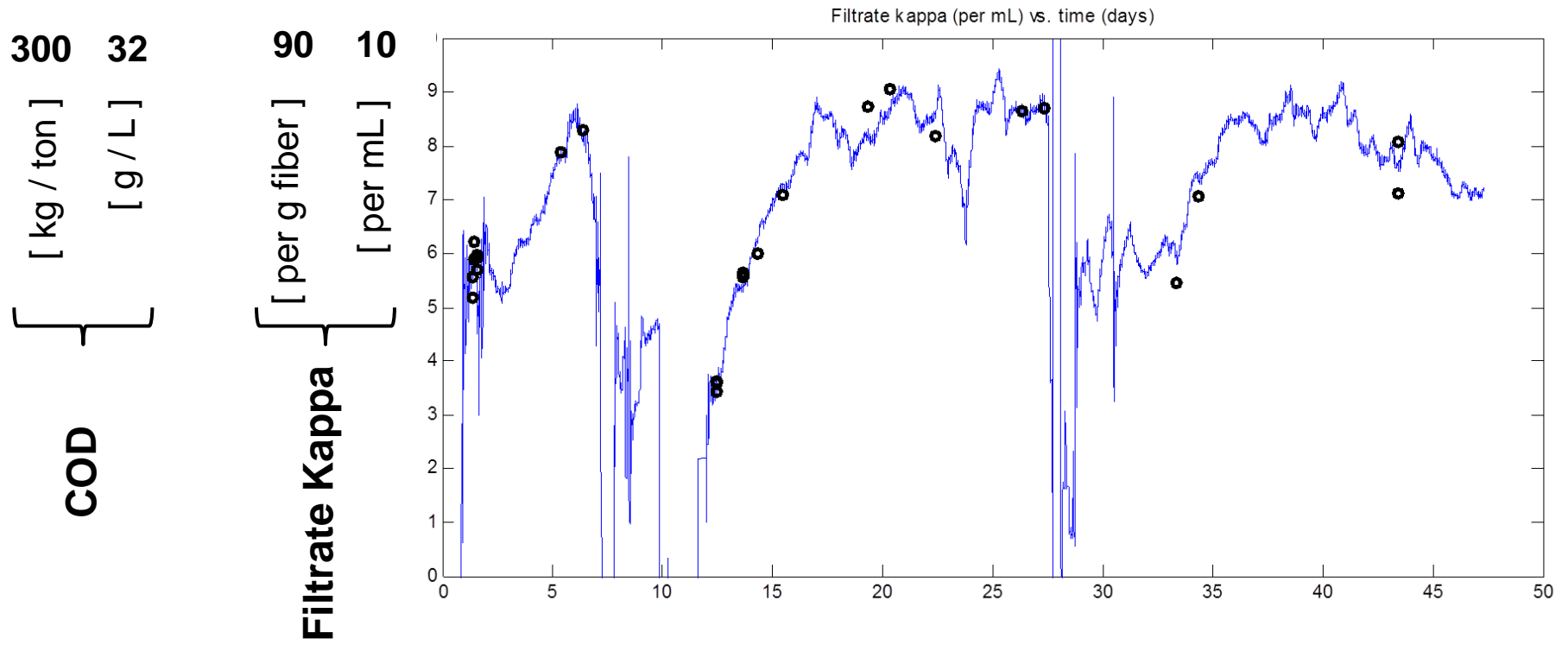

# Oxygen Delignification

- Varying COD Load (controlled); partly 'Virgin COD'
  - *Impact 2-3 Kappa units over the studied range*

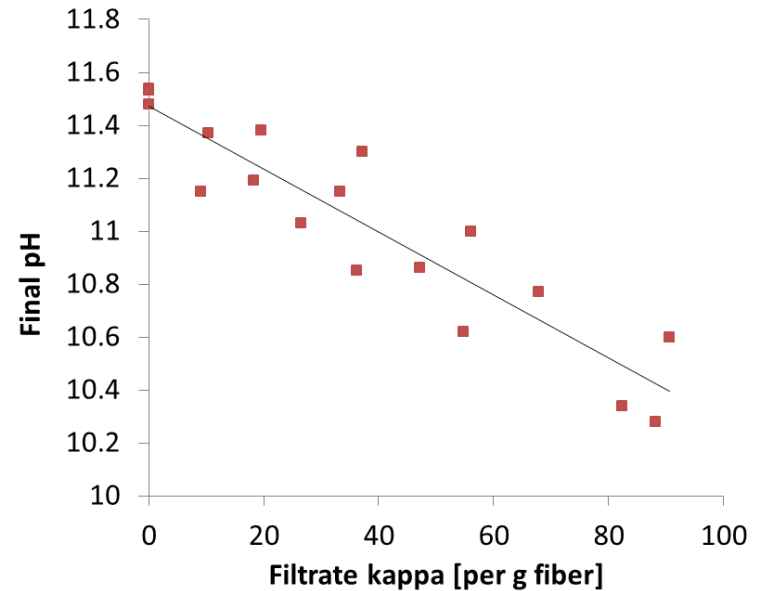
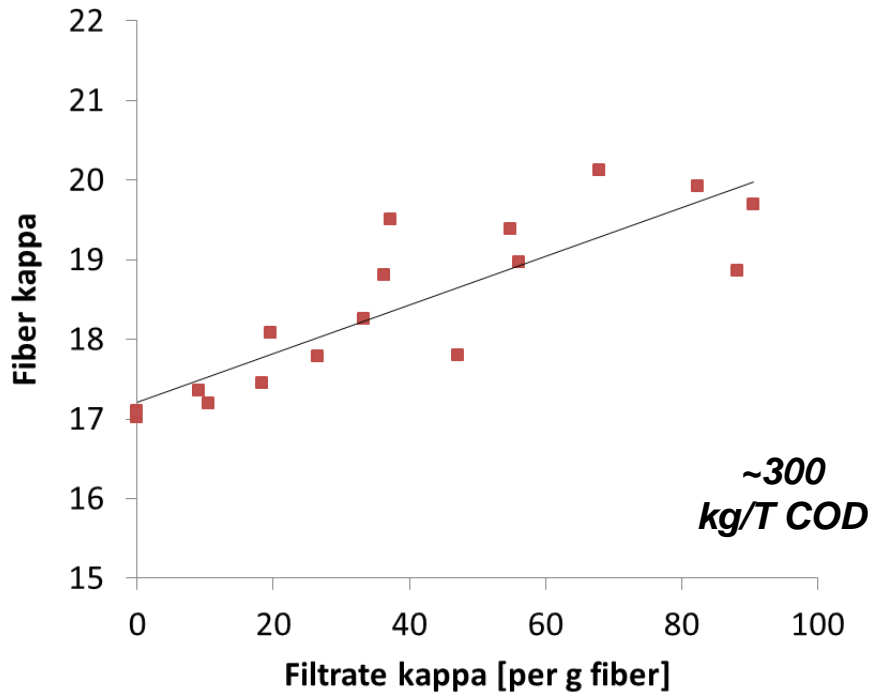

- *Significantly lower final pH at high COD Load*

# Oxygen Delignification

## *Conclusions*

---

- Significant variability in dissolved lignin carryover is typical
- Results indicate (at least) 'Virgin COD' carryover should be measured/controlled
  - Brownstock washing control/optimization
  - Feedforward O<sub>2</sub> delig control – alkali and O<sub>2</sub> charges
- Further trials planned to resolve
  - 'Virgin' vs. Recirculated COD
  - Dissolved lignin vs. alkali

# Acknowledgements

---

- Based on research by Niclas Andersson, BTG, Caroline Wilke, BTG and Karlstad University, Akhlesh Mathur, BTG and Ulf Germgard, Karlstad University
- The Swedish Knowledge Foundation
- VIPP Industrial Graduate School
  - Values created In fibre-based Processes and Products
  - Karlstad University, Sweden

KK-stiftelsen ><

